

XTH 3000-12
XTH 5000-24
XTH 6000-48
XTH 8000-48

XTM 1500-12
XTM 2000-12
XTM 2400-24
XTM 3500-24
XTM 2500-48
XTM 4000-48

XTS 900-12
XTS 1200-12
XTS 1400-48

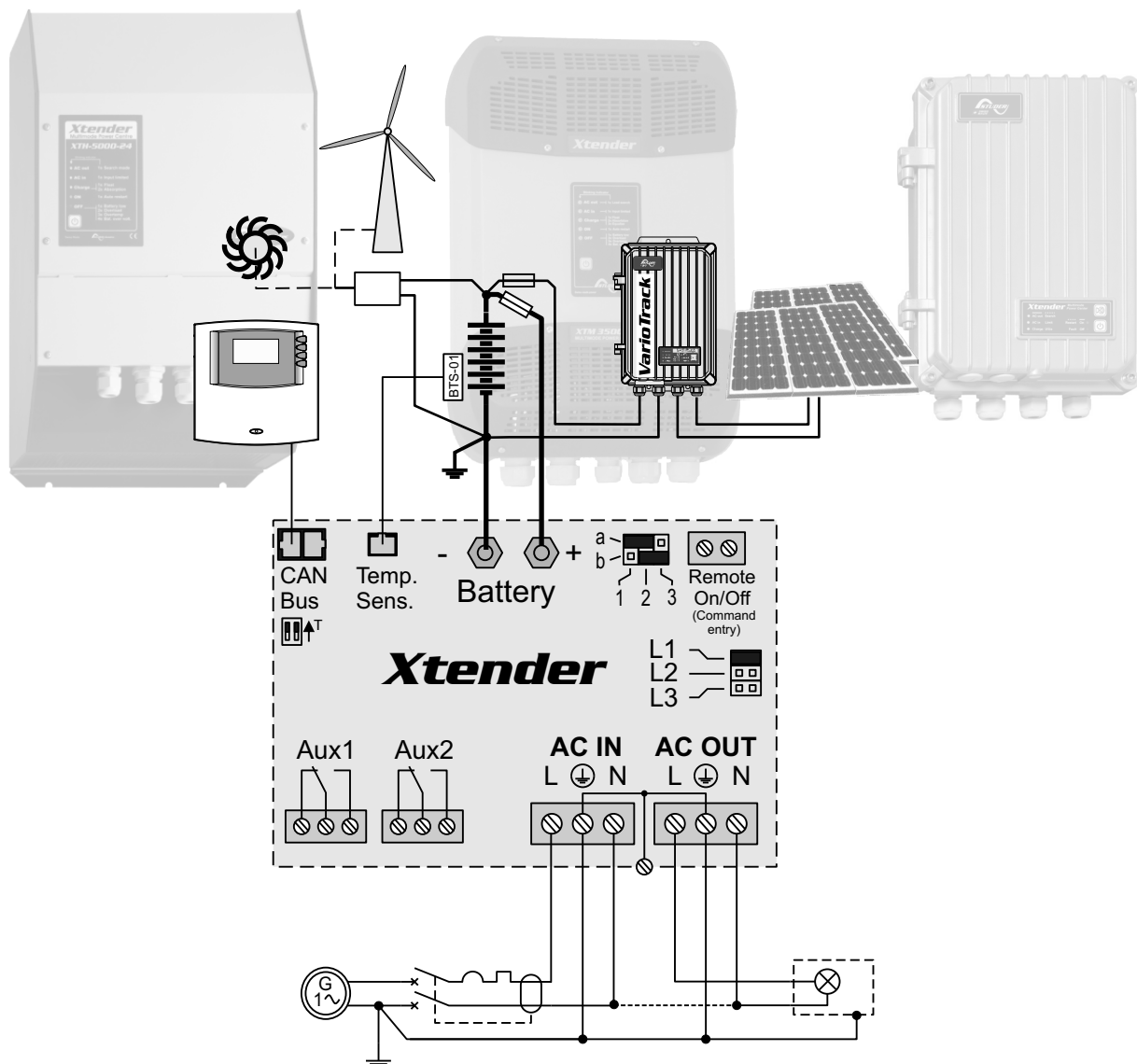

This appendix is part of the installation and user manual
 Cette annexe fait partie intégrante du manuel d'utilisation
 Dieser Anhang ist ein wesentlicher Bestandteil des Betriebsanleitung
 Este anexo es parte integrante del manual de utilización

NOTE IMPORTANTE

Cette annexe au manuel est commune à toutes les langues et doit être conservée avec le manuel de la langue de votre choix.

Pour la bonne compréhension de ce document, vous devez vous référer aux commentaires des éléments référencés par des lettres ou des chiffres dans les chapitres suivants du manuel :

Référence :	chap.	commentaires
Figures	15	Intitulés et commentaires des schémas (Figures)
Lettre minuscule	16	Eléments des figures partie DC
Lettre majuscule	17	Eléments des figures câblage AC
Chiffre 1 à 22	3.6.4	Elément du compartiment de raccordement
Chiffre 25 à 29	18	Dimension mécanique et éléments de montage
Chiffre 30 à 40	19	Eléments de l'étiquette d'identification

IMPORTANT NOTE :

This appendix to the manual is common to all languages and must be kept with the manual of your choice.

For the good understanding of this document, you should refer to the comments about elements referenced by letters or numbers in the chapters of the manual mentioned in the below table:

Référence :	Sect.	comments
Figures	15	Comments on drawings (Figures)
Lower-case character	16	Parts (components) of figures DC
Upper-case character	17	Parts (components) of figures AC cabling side
Number 1 to 22	3.6.4	Elément du compartiment de raccordement
Chiffre 25 to 29	18	Mechanical dimension and mounting elements
Chiffre 30 to 40	19	Wording of identification plate

WICHTIGE ANMERKUNG :

Dieser Anhang zum Bedienerhandbuch ist für alle Sprachen identisch und muss mit dem entsprechenden Bedienerhandbuch aufbewahrt werden.

Für ein gutes Verständnis dieses Dokuments halten Sie sich an die folgenden Kapitel des Bedienerhandbuchs :

Referenz :	kap.	Kommentare
Figuren	15	Kommentare der Schemas (Figuren)
alphabetische Kleinbuchstaben	16	Elemente der Figuren des DC Teil
alphabetische Grossbuchstaben	17	Elemente der Figuren des AC
Nummer 1 bis 22	3.6.4	Anschlusselemente
Nummer 25 bis 29	18	Dimension mécanique et éléments de montage
Nummer 30 bis 40	19	Elemente der Identifikationsetikette

NOTA IMPORTANTE:

Este anexo al manual es común a todos los idiomas y debe conservarse con el manual del idioma que ha elegido.

Para la buena comprensión de este documento, debe referirse a los capítulos siguientes del manual:

Référence :	cap.	comentarios
Esquemas (fig.)	15	Los comentarios de los esquemas (Figuras)
caracteres en minúscula	16	Elementos de figuras parte DC
caracteres en mayúscula	17	Elementos de figuras cableado AC
cifras 1 a 22	3.6.4	Elementos de conexiones
cifras 25 a 29	18	Dimensiones mecánicas y accesorios de montaje
cifras 30 a 40	19	Elementos de la etiqueta de identificación

Fig. 1a

Model and specification tag

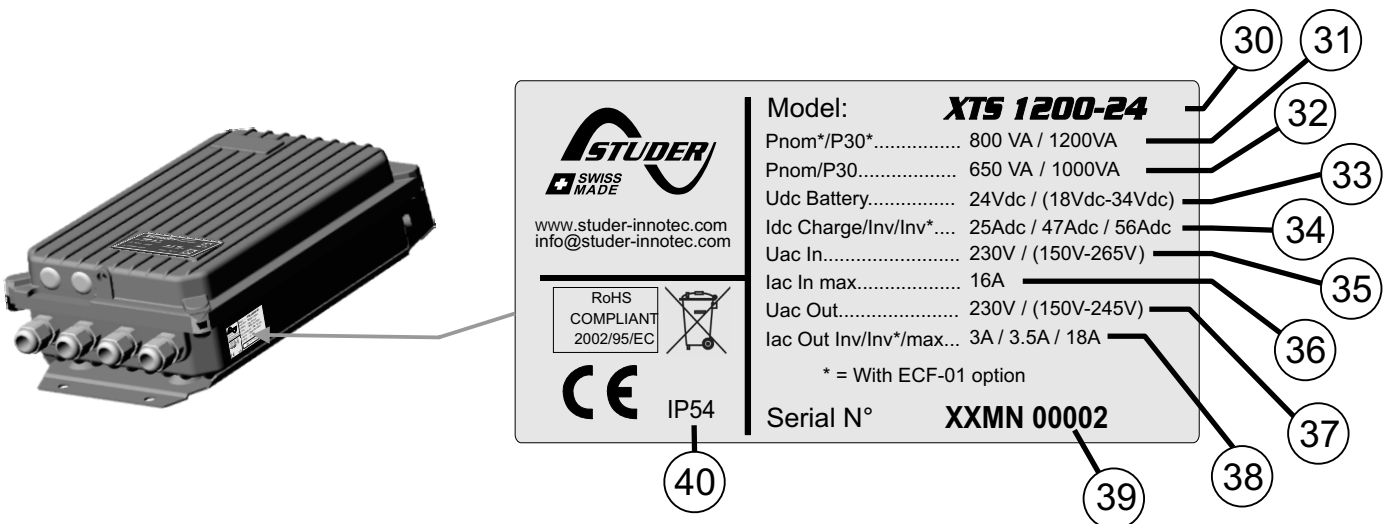
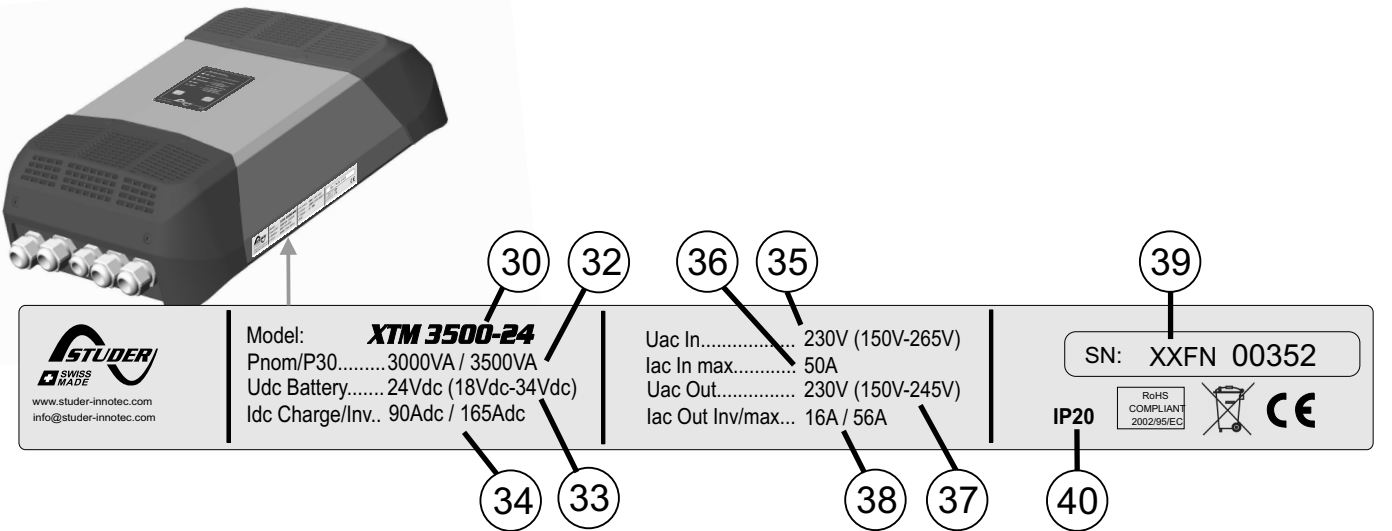
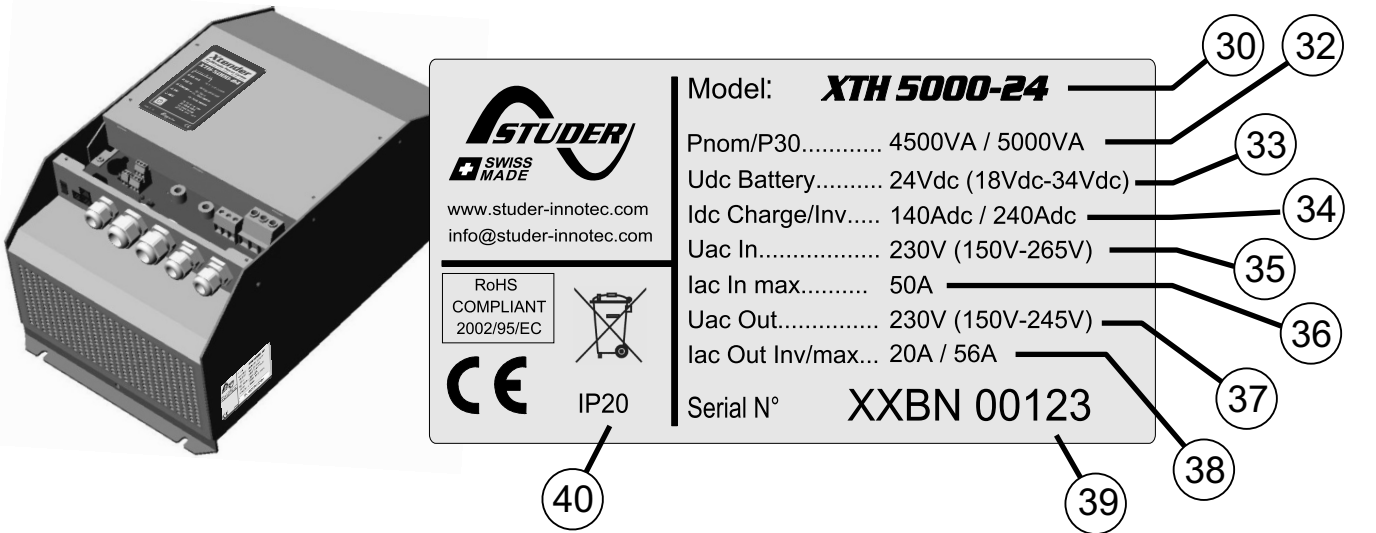
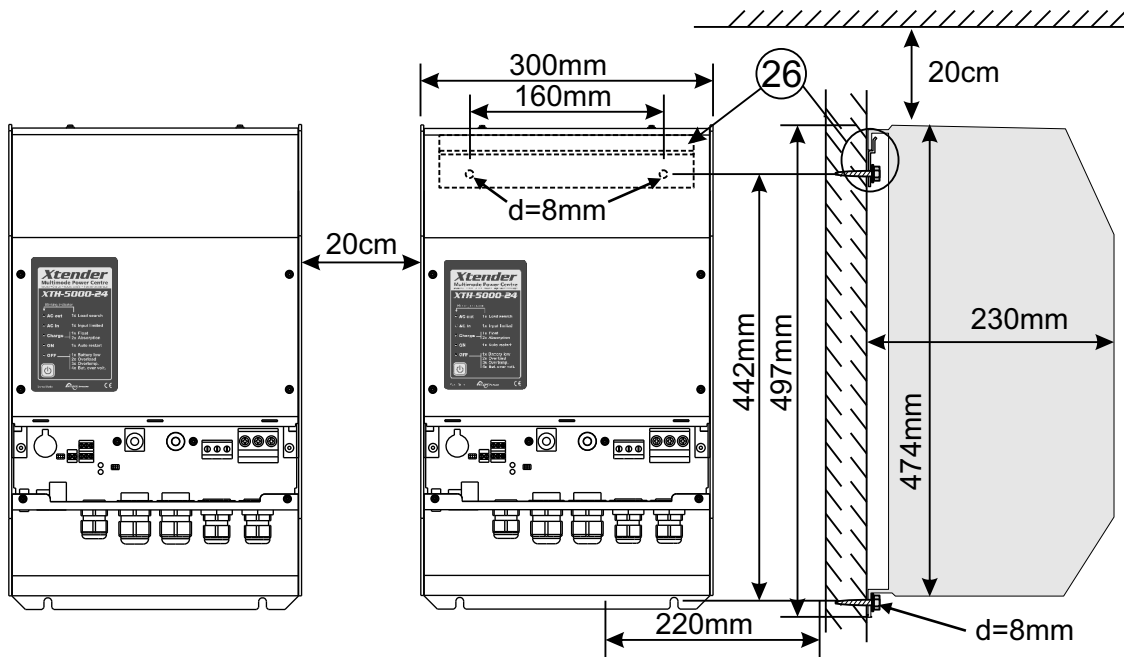

Fig. 2a

Dimension, clearance and affixing

XTH



XTS

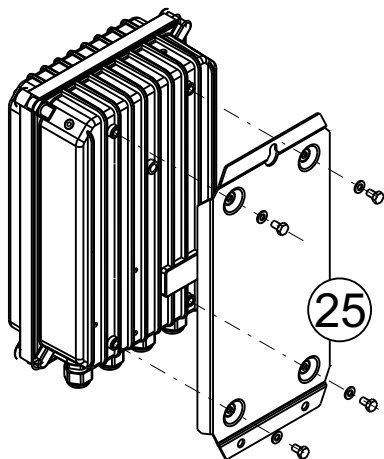
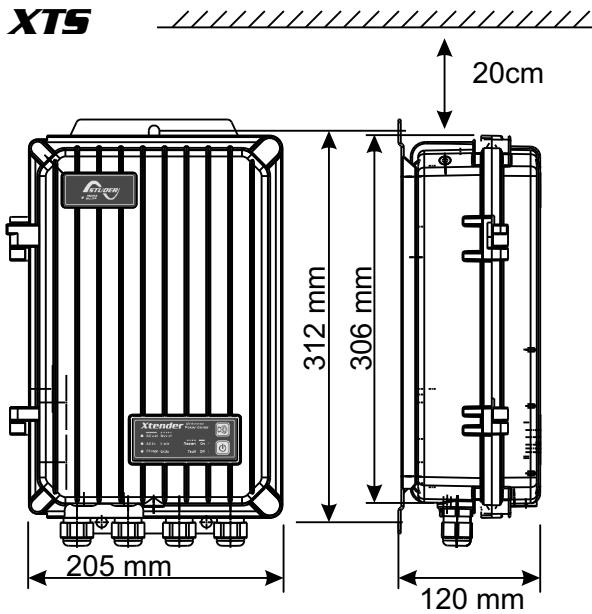

XTM

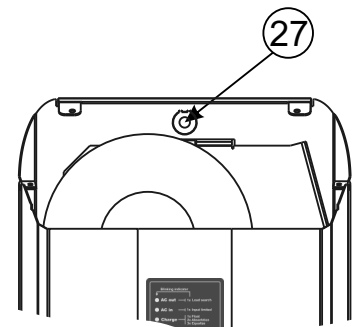
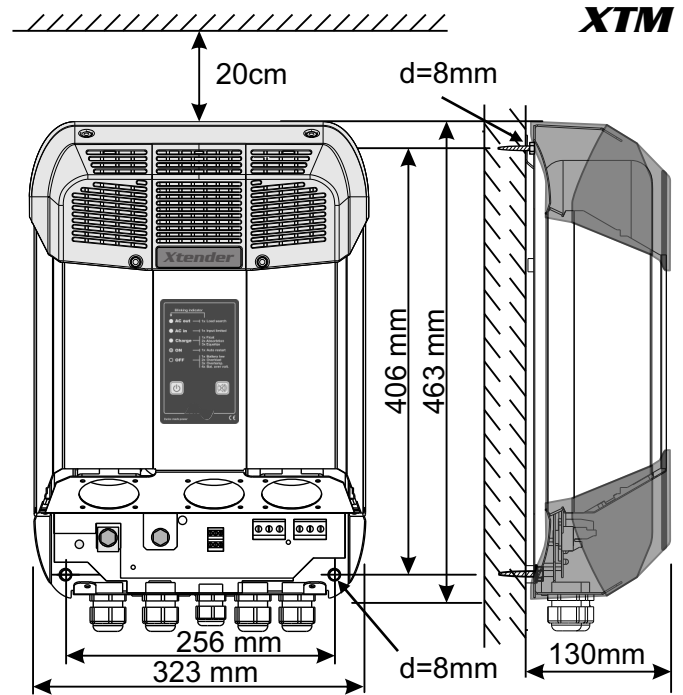

Fig. 5a

12V battery bank wiring with 2Vcell in series and parallel+series

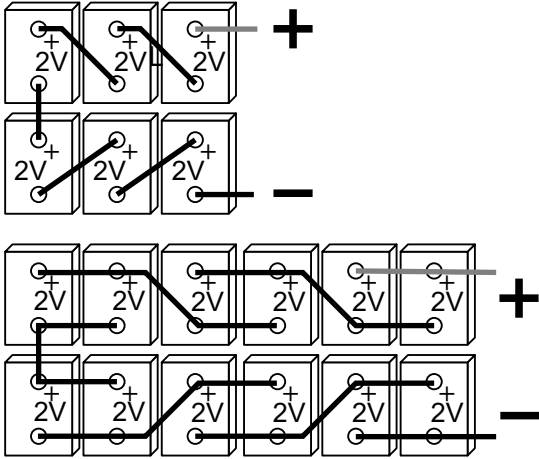

Fig. 5b

12V battery bank wiring with single and parallel 12Vcell

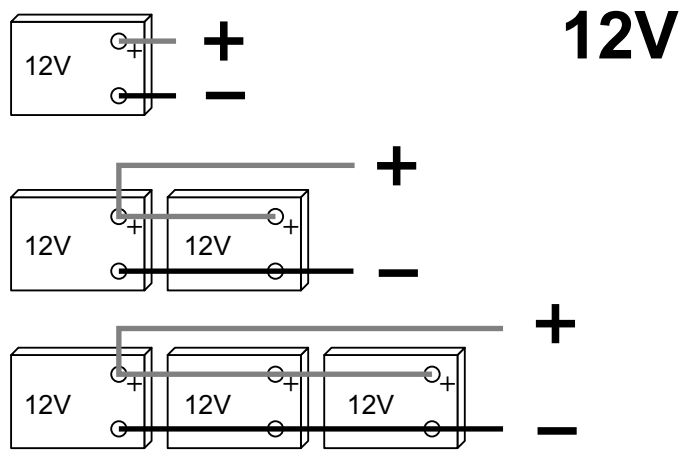

Fig. 5c

24V battery bank wiring with 2Vcell in serie and parallel+series

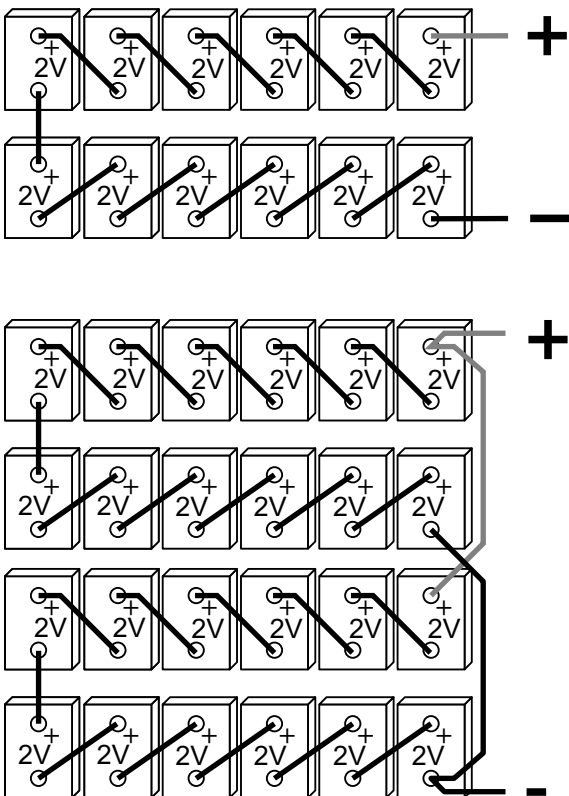

Fig. 5e

24V battery bank wiring with series and series/parallel 12Vcell

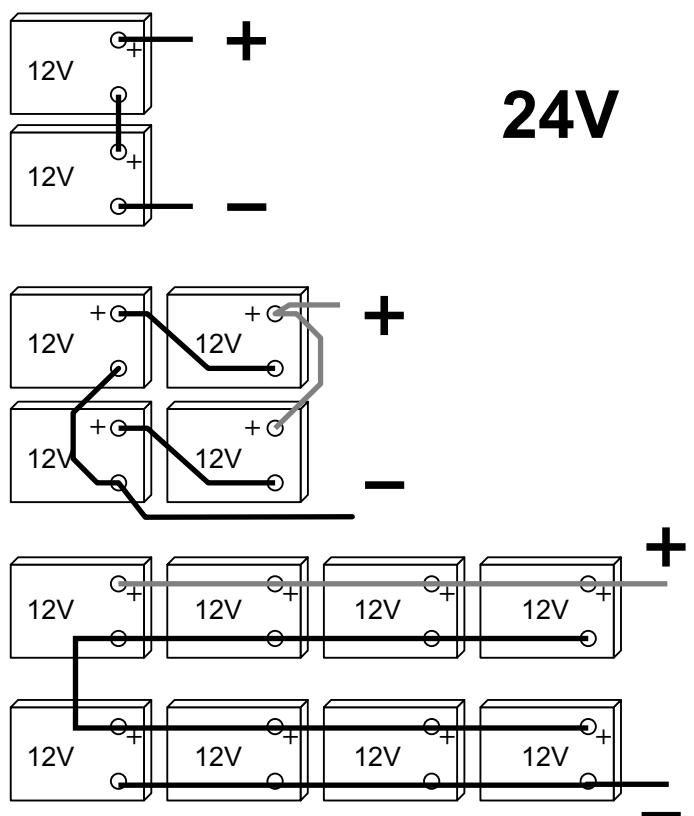

Fig. 6a 48V battery bank wiring with series/parallel 12Vcells

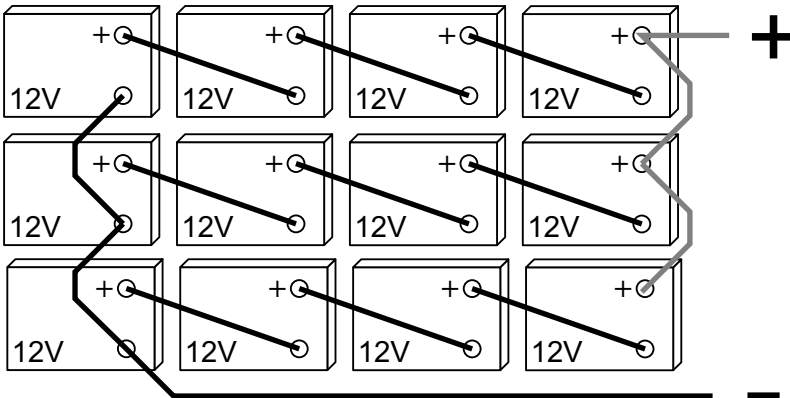

Fig. 6b

48V battery bank wiring with series 12Vcells

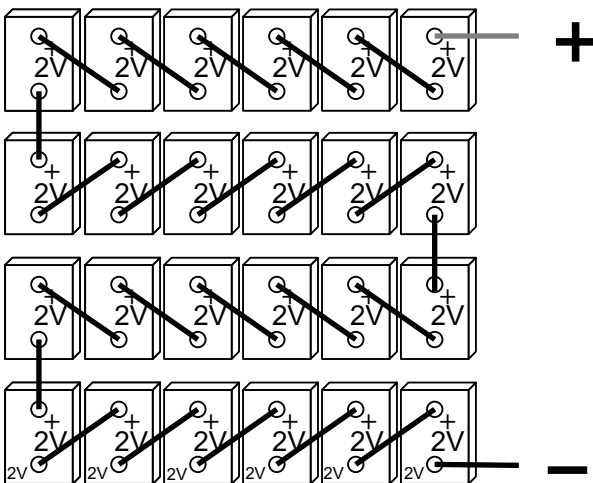
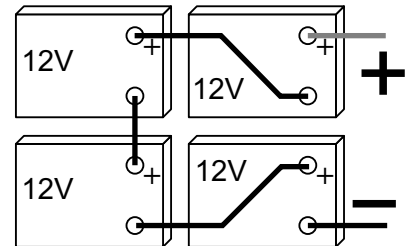
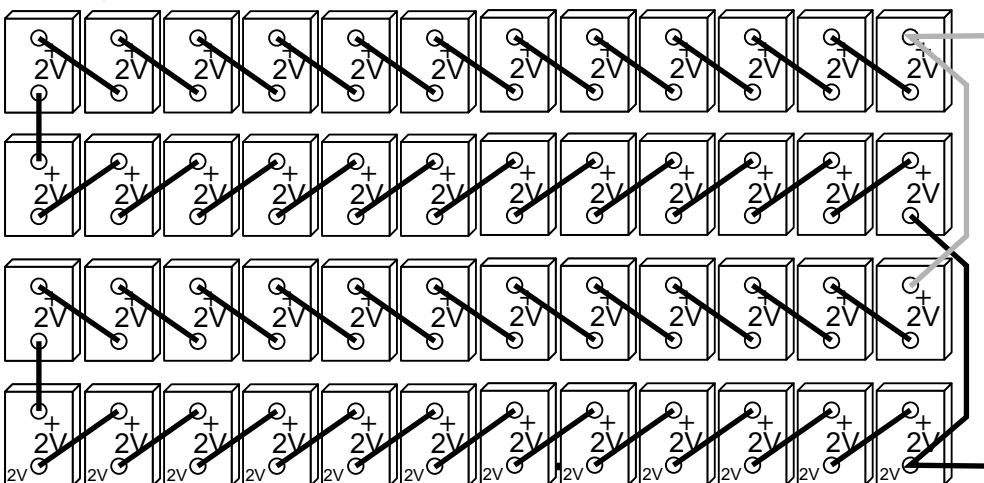

Fig. 6c

48V battery bank wiring with 24 x 2Vcells in series

Fig. 6d



+

48V battery bank wiring with 2 parallelled strings of 24 x 2V cells

-

Fig. 7a

Xtender XTS principle and equivalent schematic

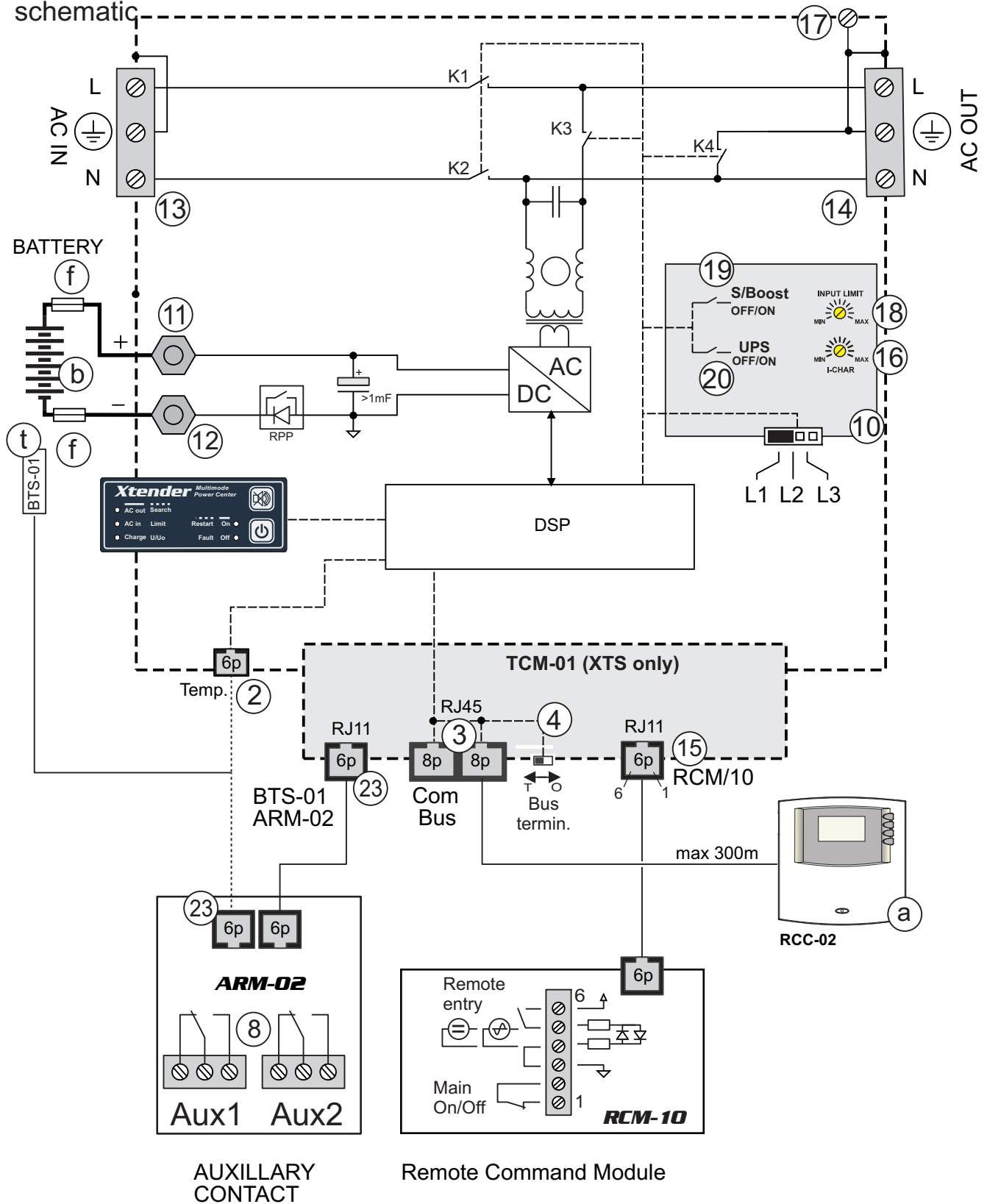

Fig. 7b Xtender principle and equivalent schematic **XTH/XTM**

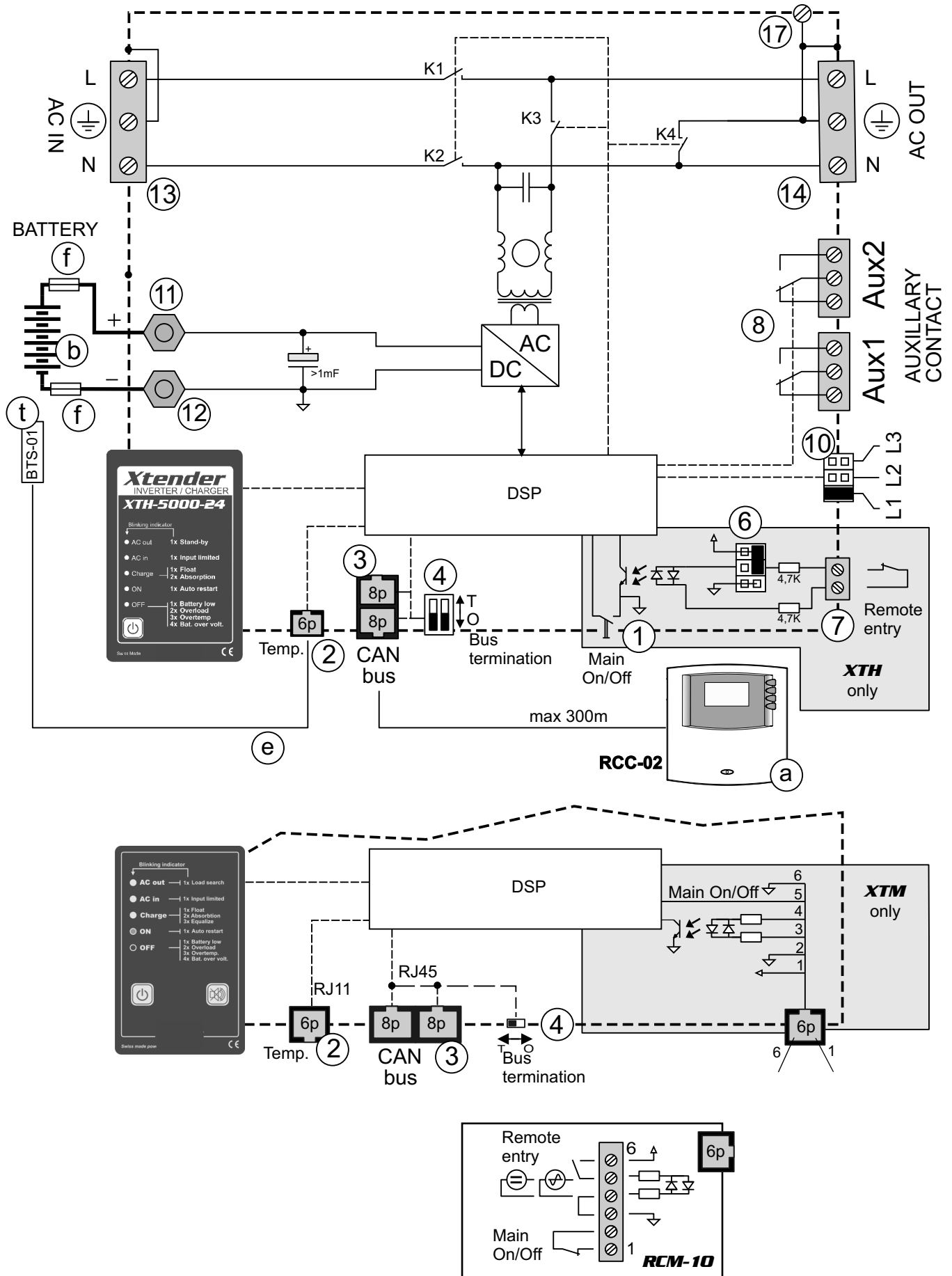

Fig. 8a

Wiring exemple of a single phase system (AC and DC side).

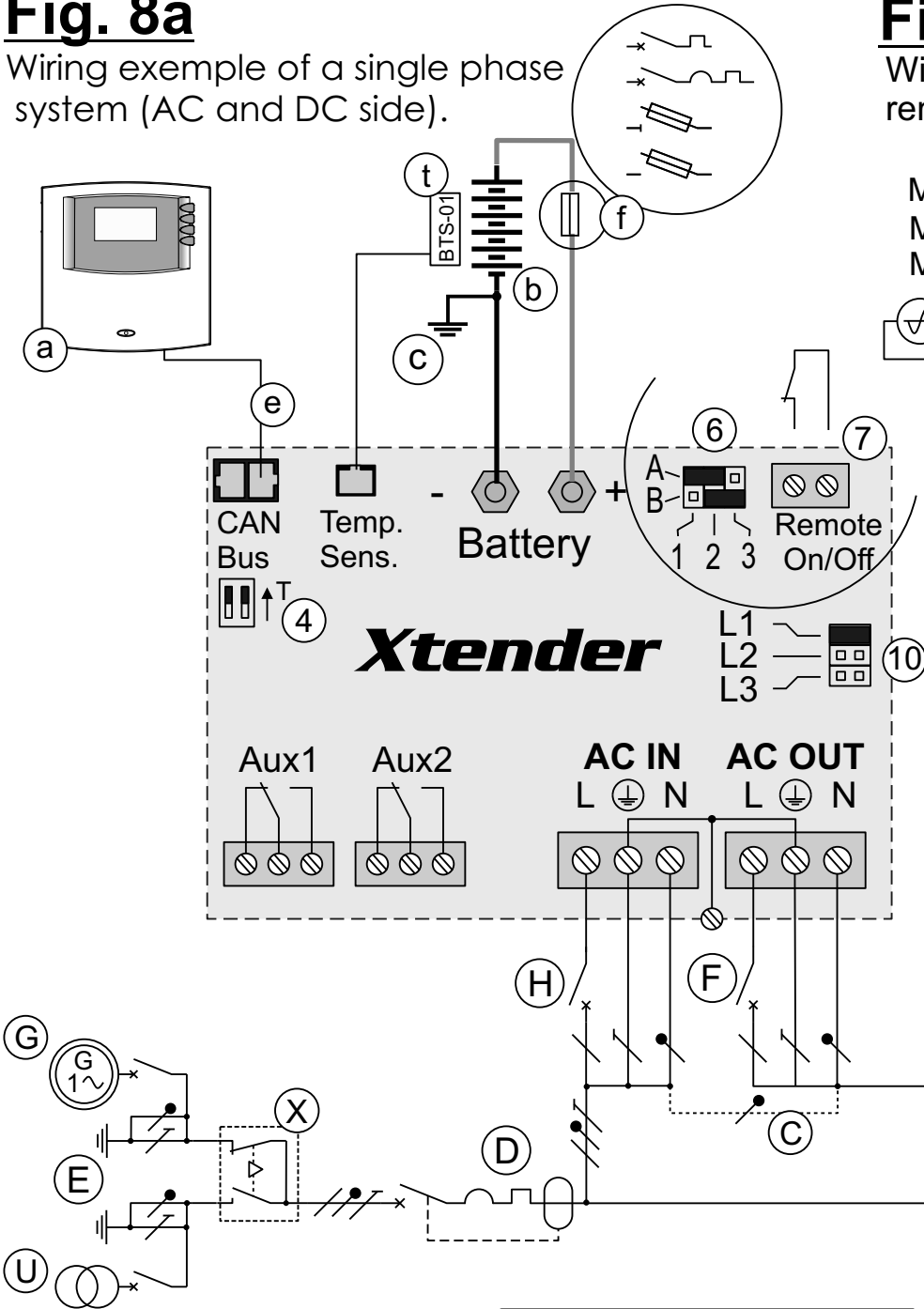

Fig. 8b

Wiring variants for remote control ON/OFF

Max.length:5m.
Max.U: 60 Veff
Max. I < 30mA

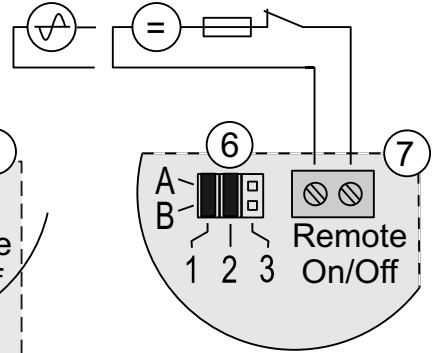

Fig.8c

Wiring exemple of a three-phase in/single phase out system (AC)

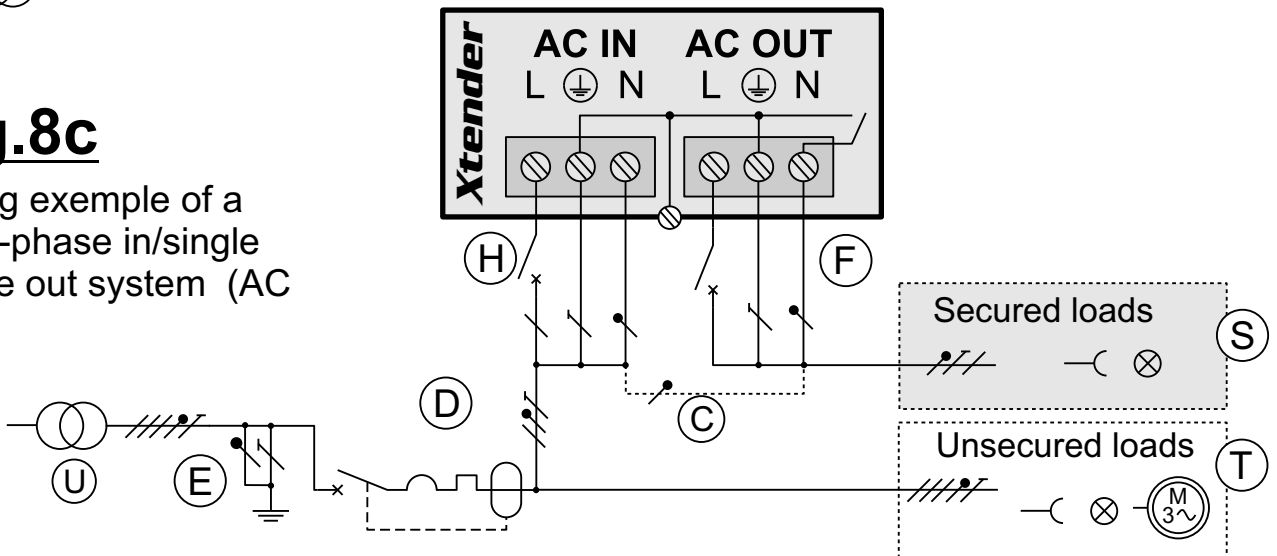

Fig. 9a

Wiring example of single phase with plugged generator

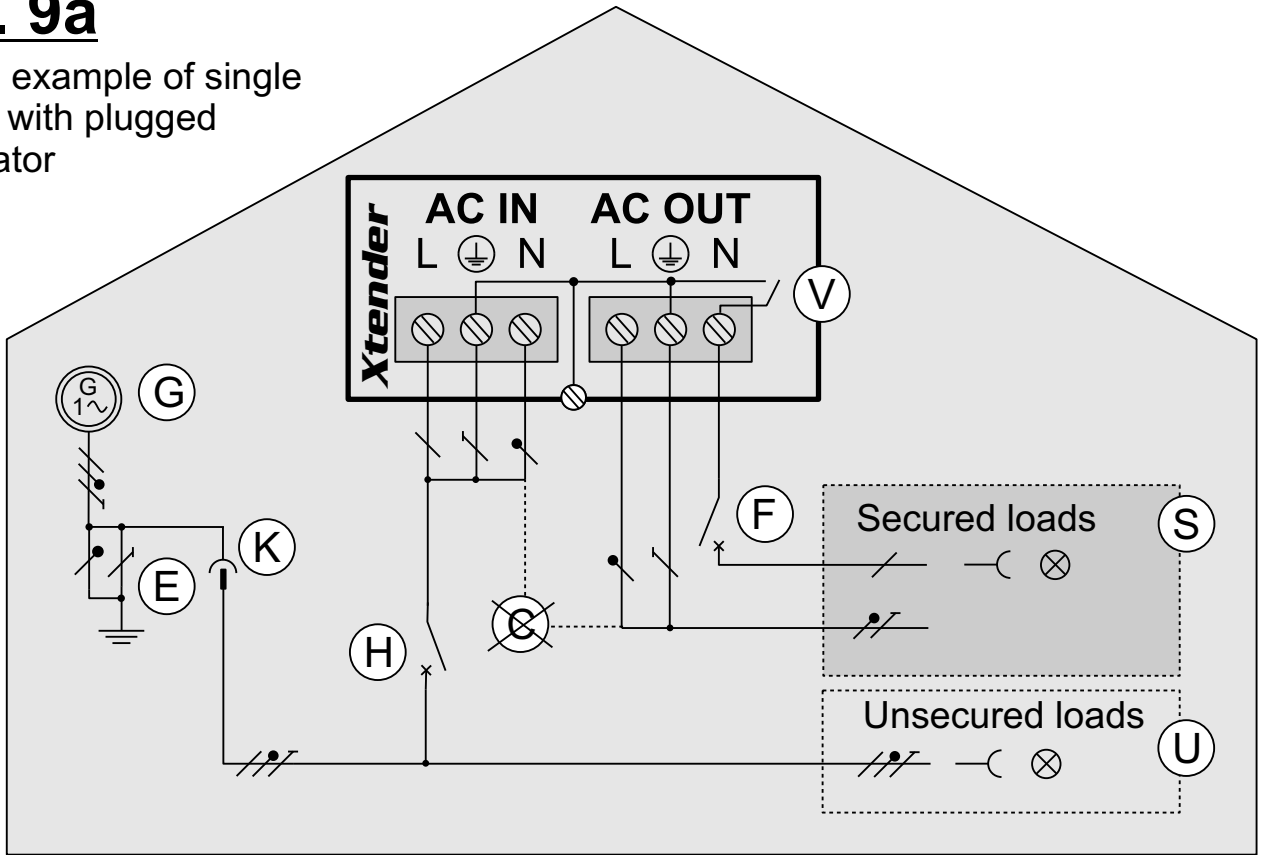

Fig. 9b

Wiring example of triphase in with plugged Xtender

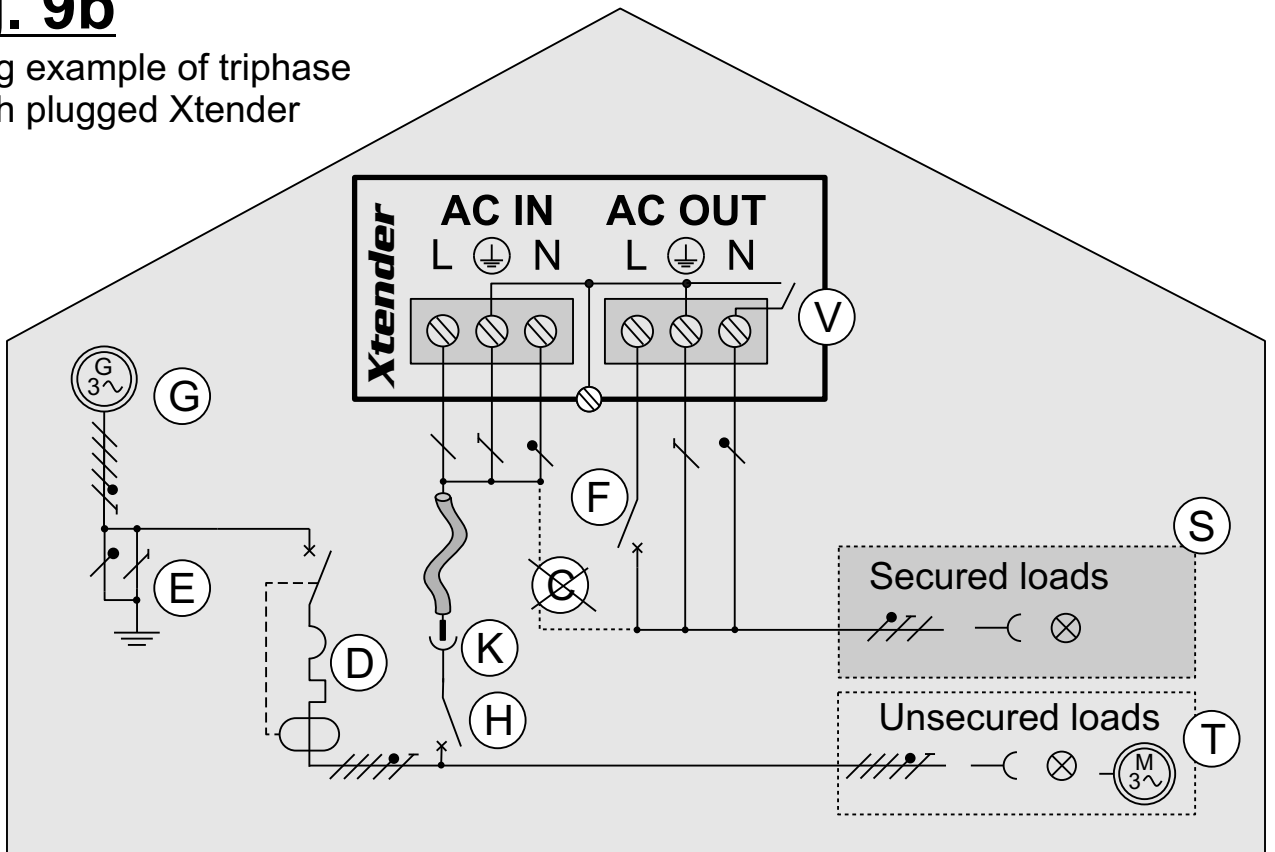

Fig. 10a

Wiring example of a vehicle pluggable on AC grid

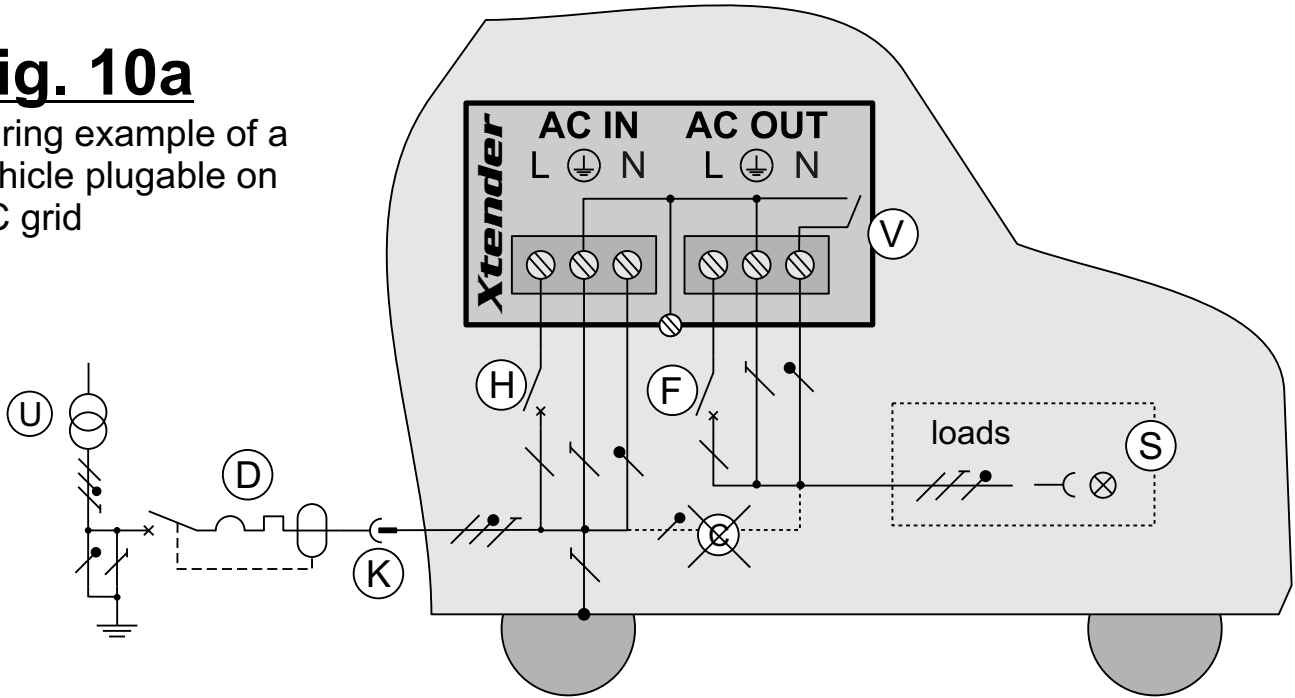

Fig. 10b

Wiring example of a boat pluggable on shore AC source without isolation transformer

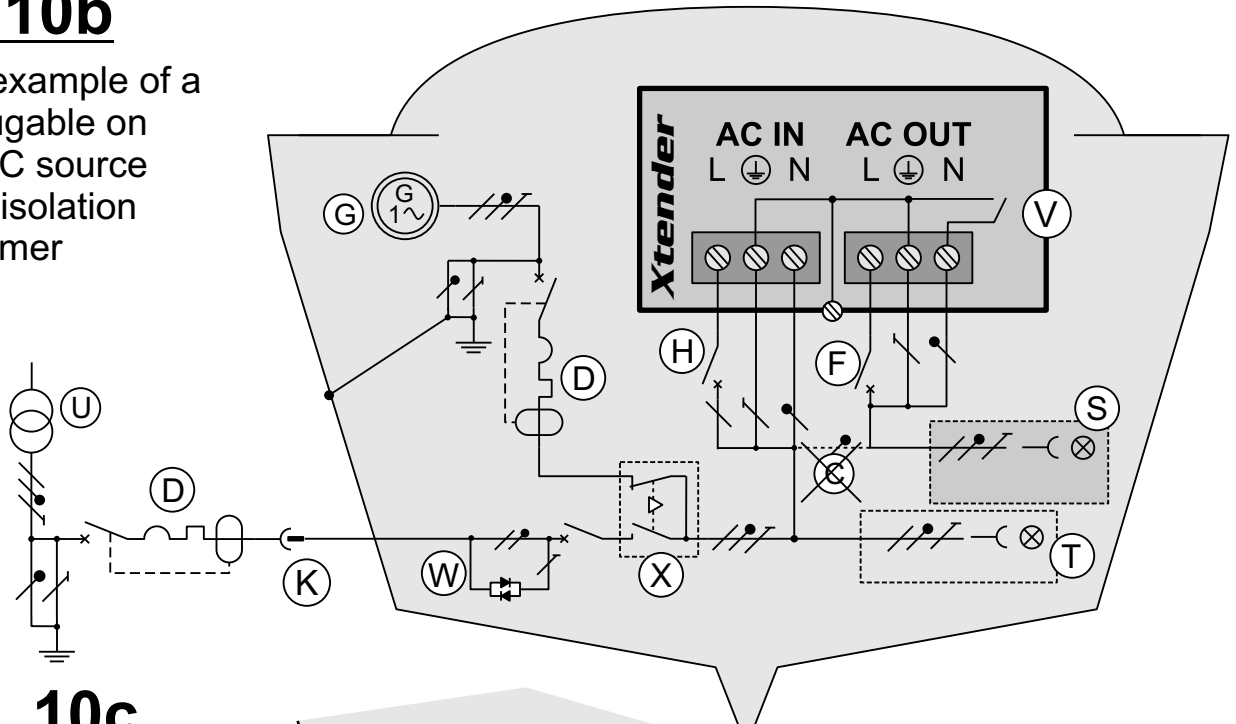

Fig. 10c

Wiring example of a boat pluggable on shore AC source with isolation transformer

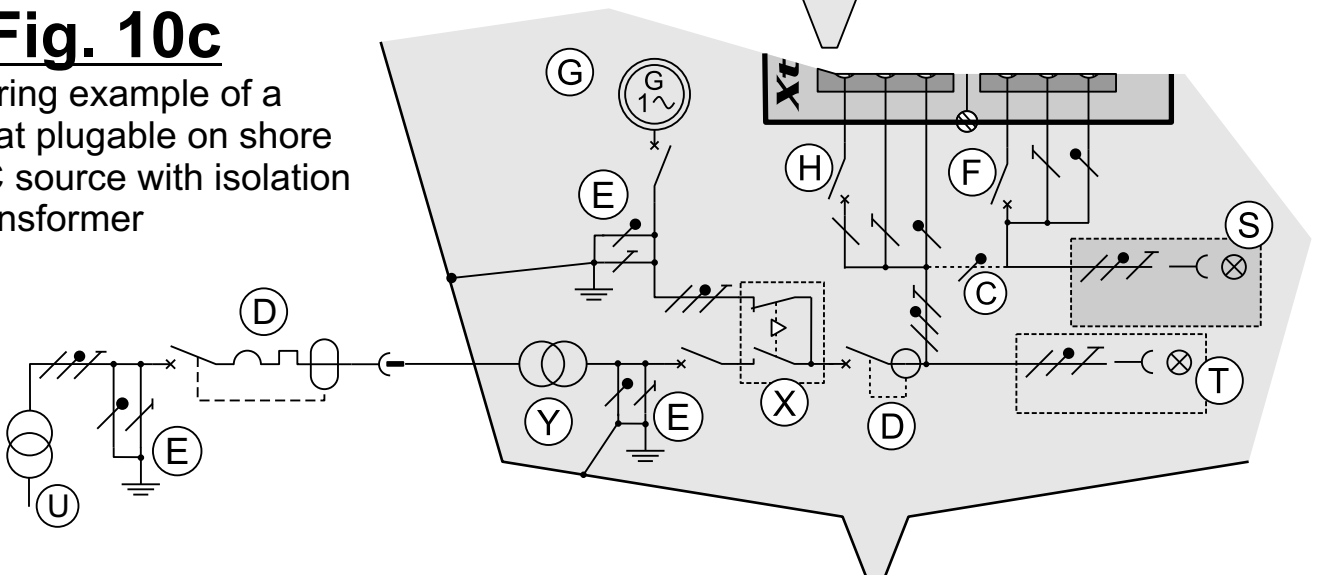

Fig. 11

Wiring example of a hybrid system with PV, wind or hydro source

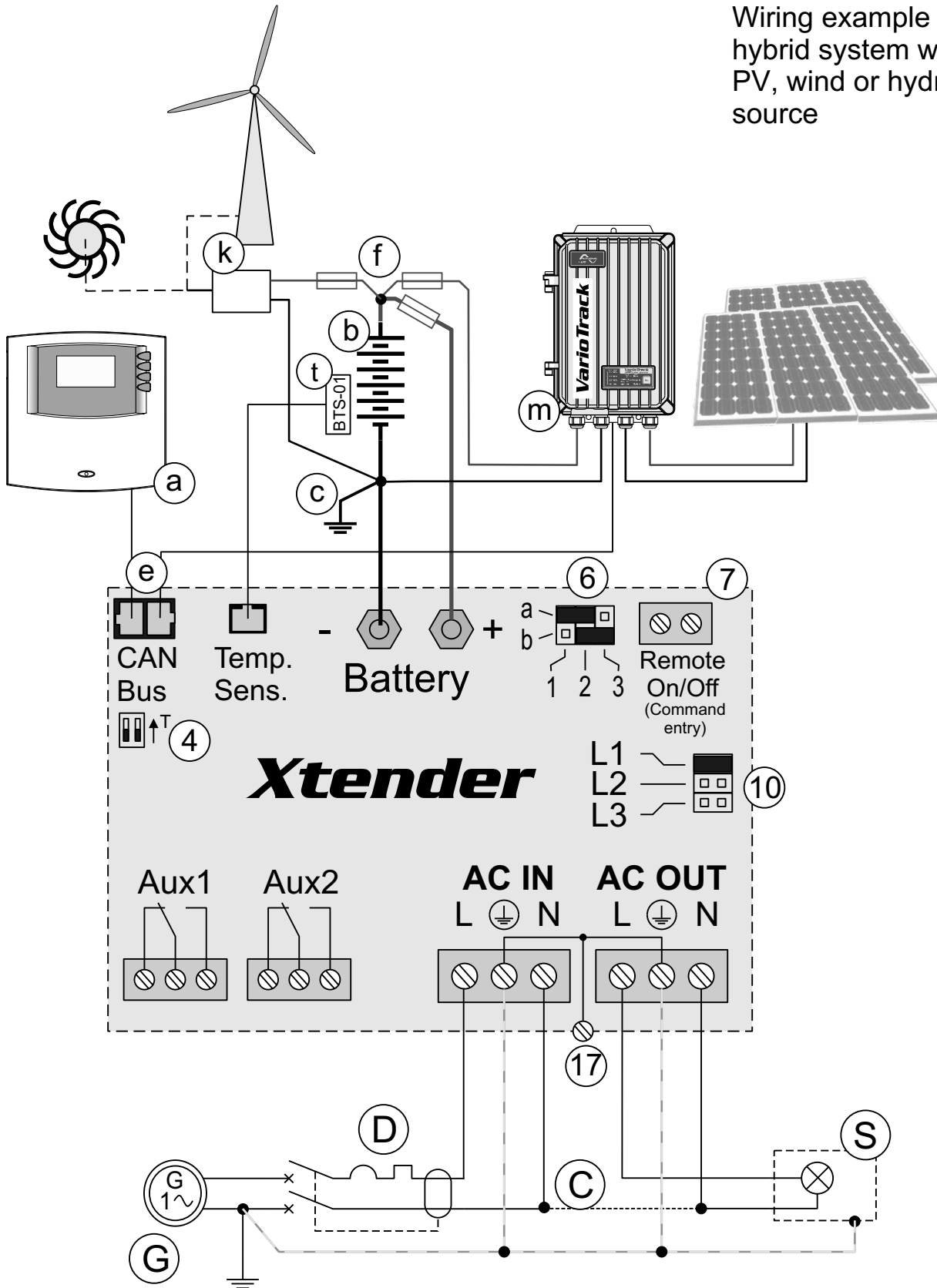

Fig. 12

Wiring example of 3 units paralleled in single phase

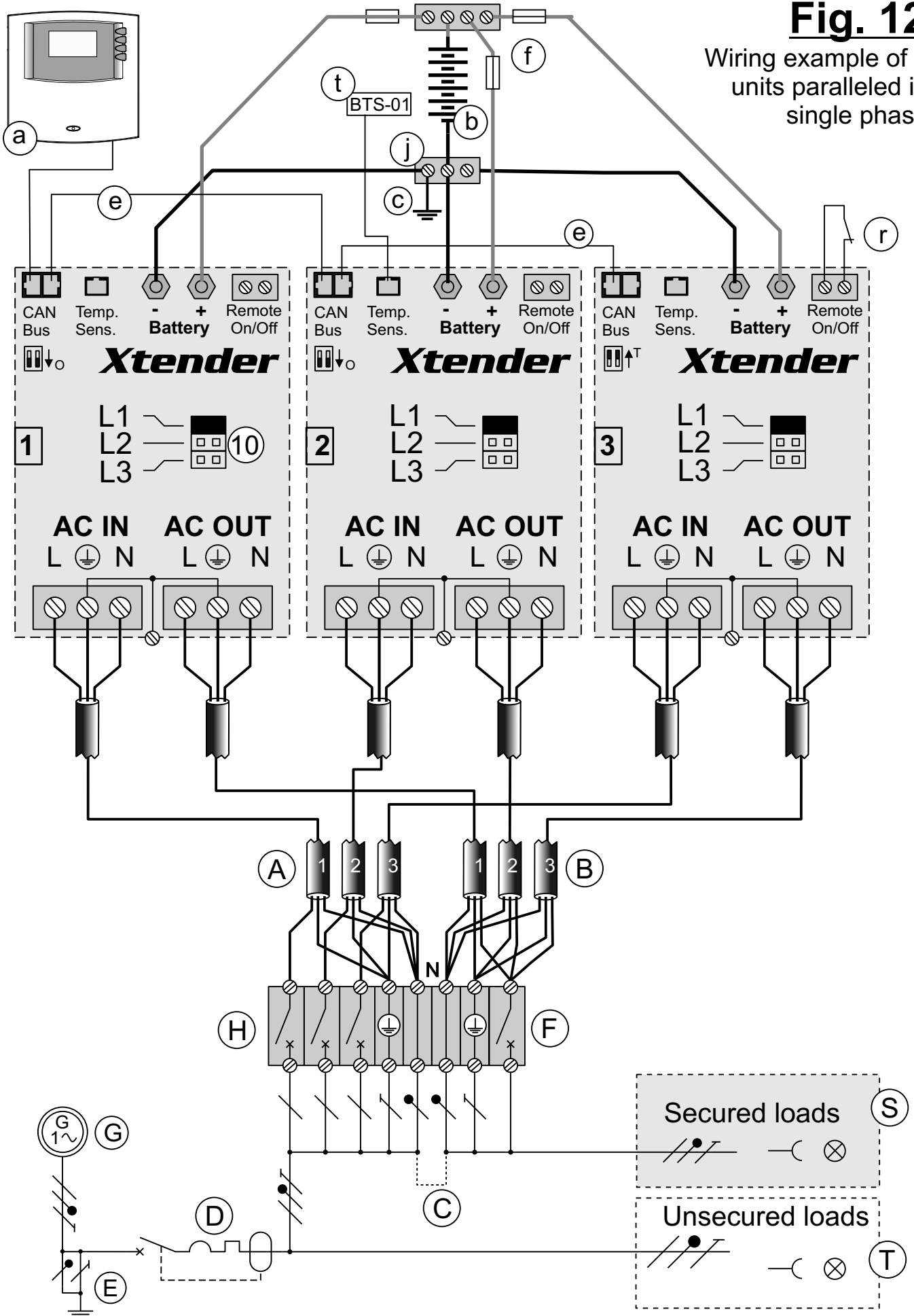

Fig. 13

Wiring example of 3 units in three-phase

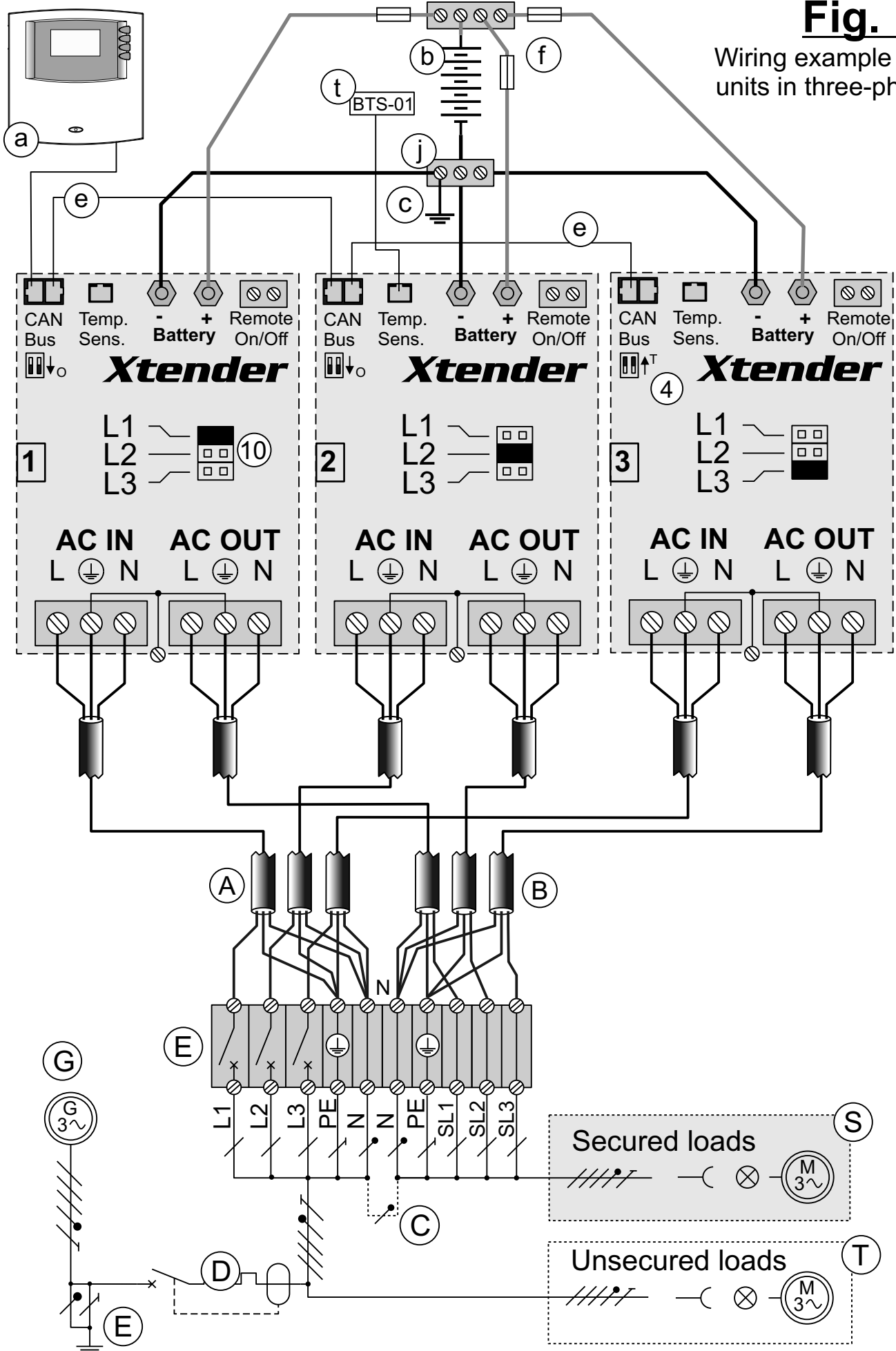

Fig. 14

Wiring example of 3 units in three-phase with single phase AC source

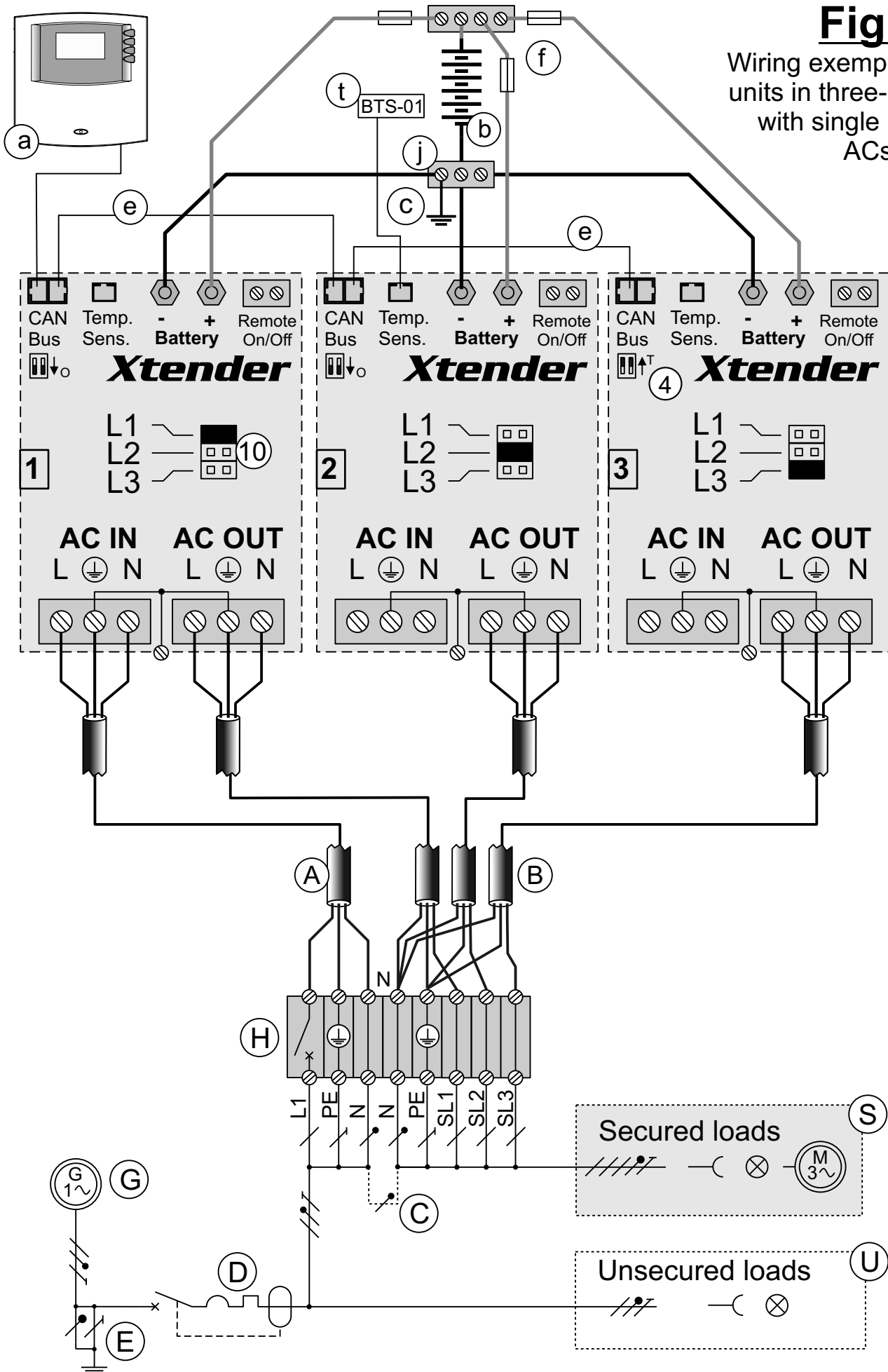

Fig. 15 Wiring example of 3 units in three-phase + one phase (L3) paralleled

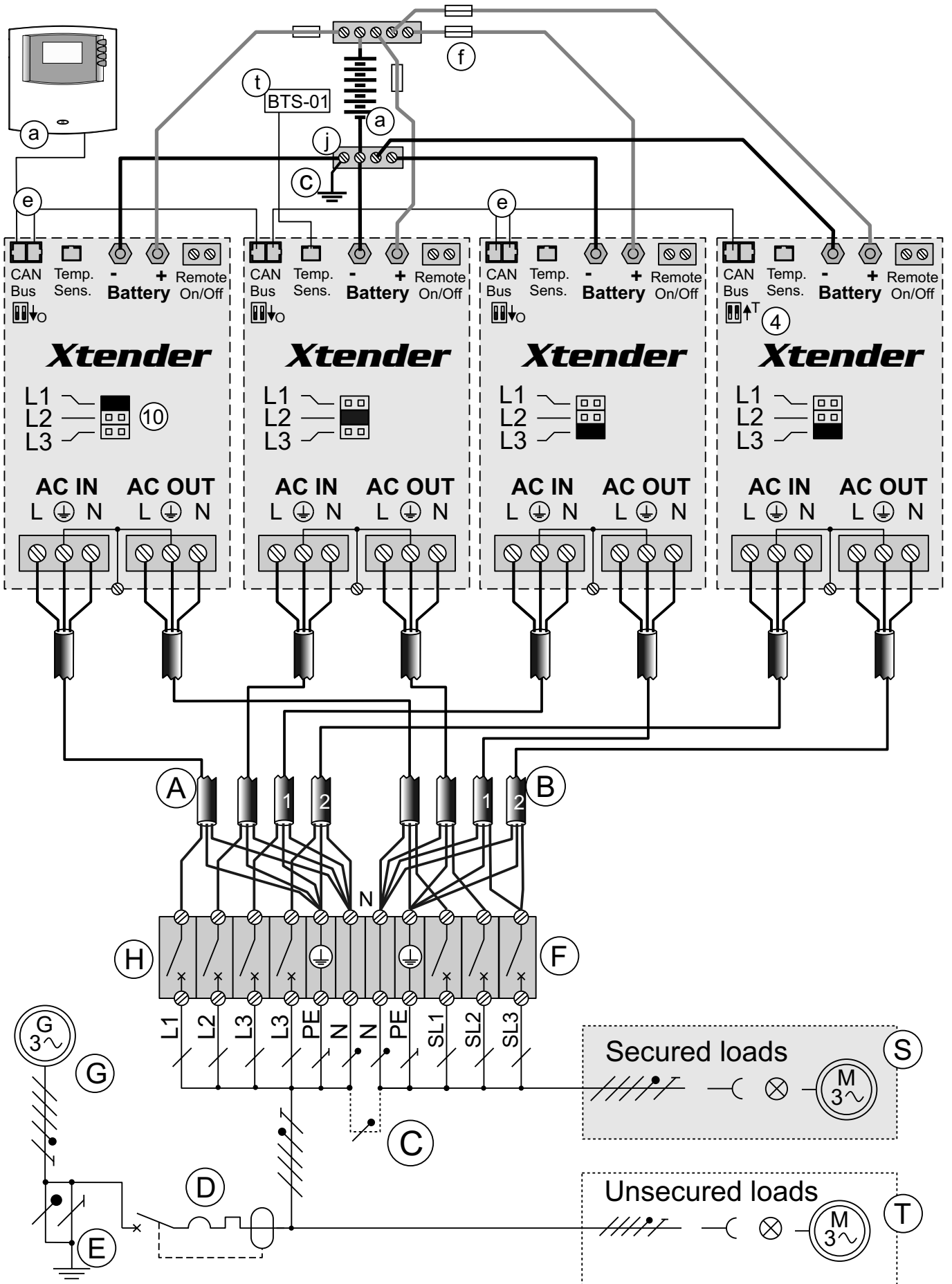

Fig. 16

Wiring example of 3 units paralleled and in three-phase

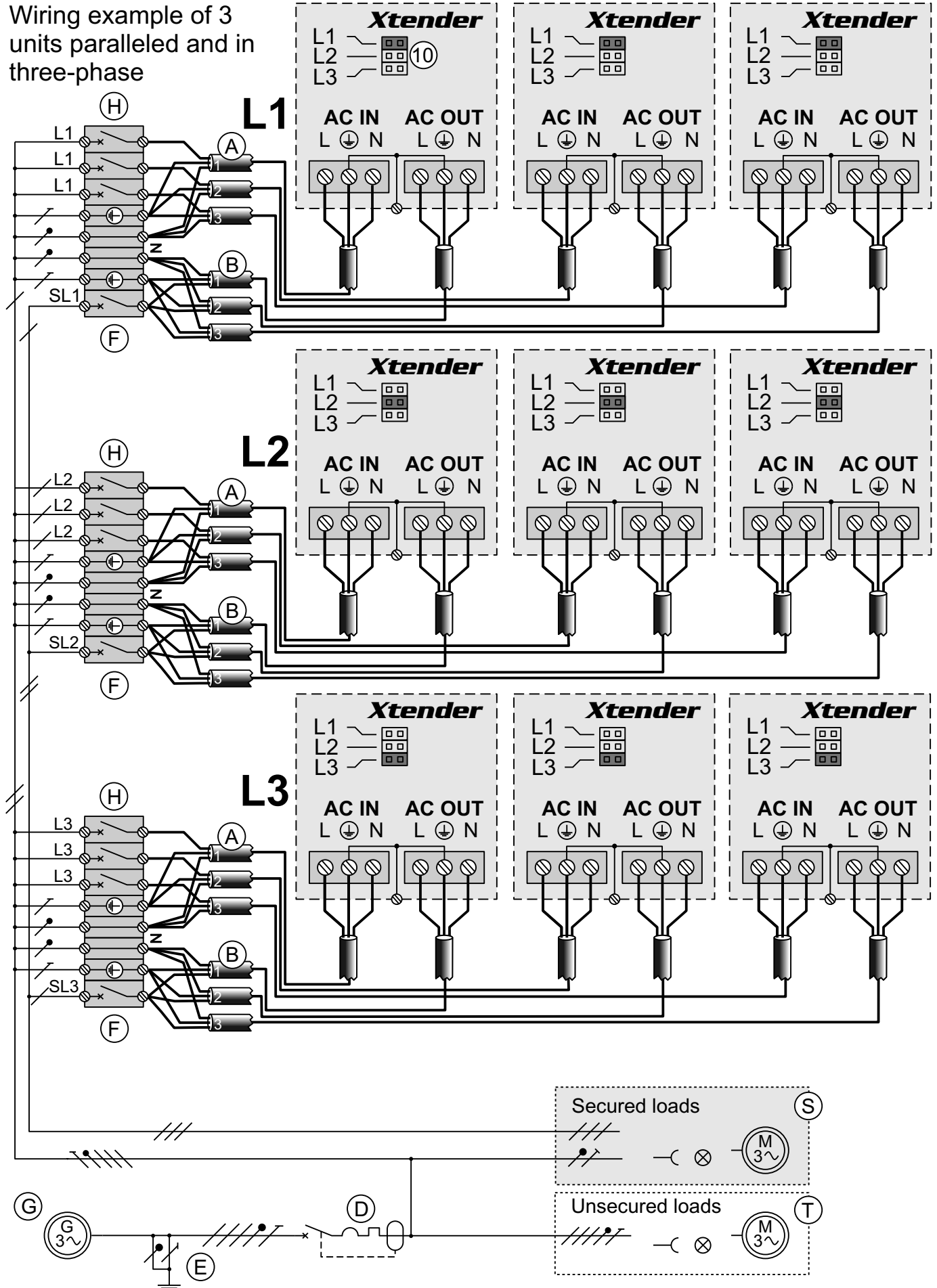

Fig. 17

DC bus wiring example of 3 units paralleled and in three-phase

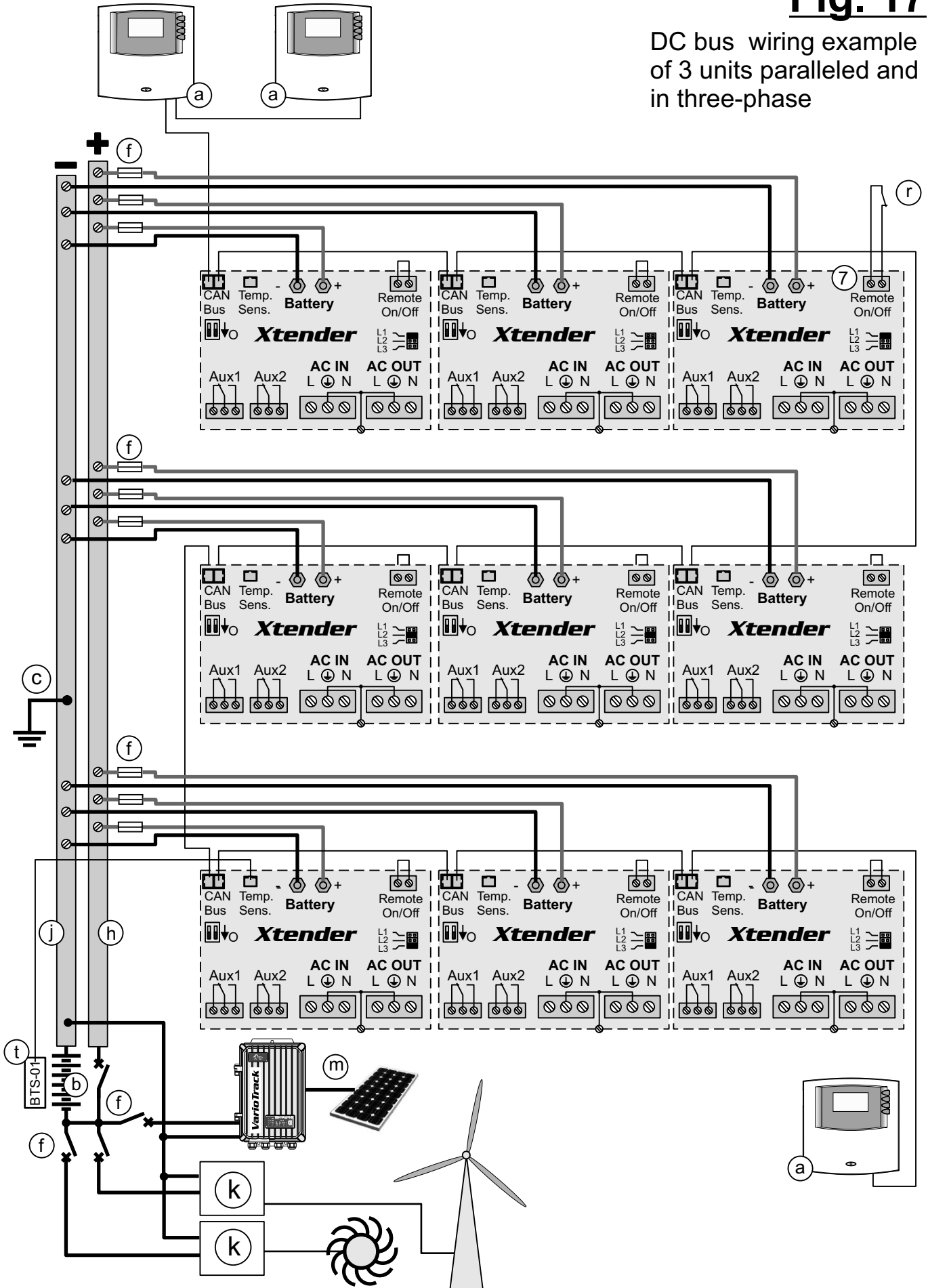

Fig. 18

DC side star wiring example of 3 units paralleled and in three-phase

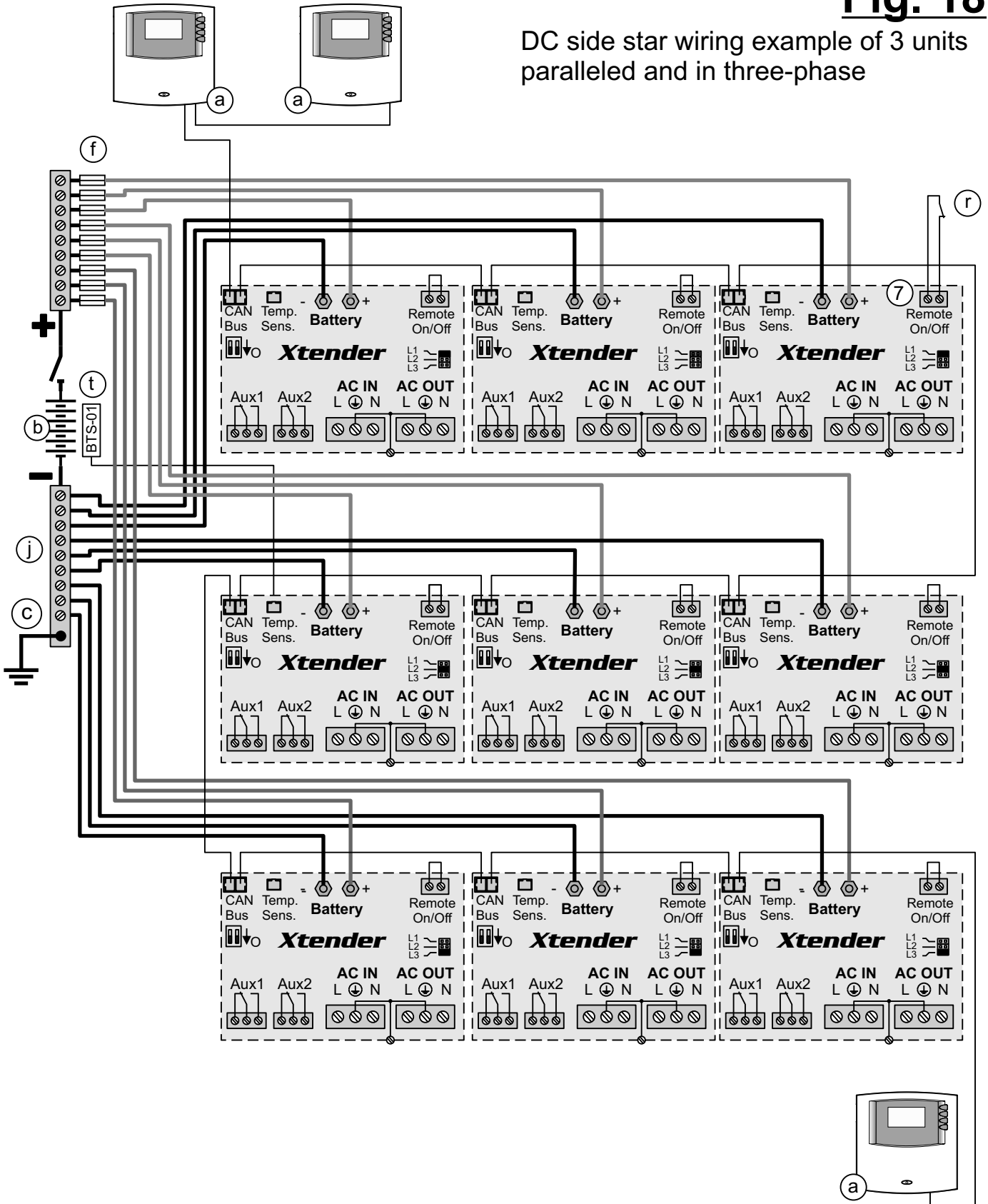
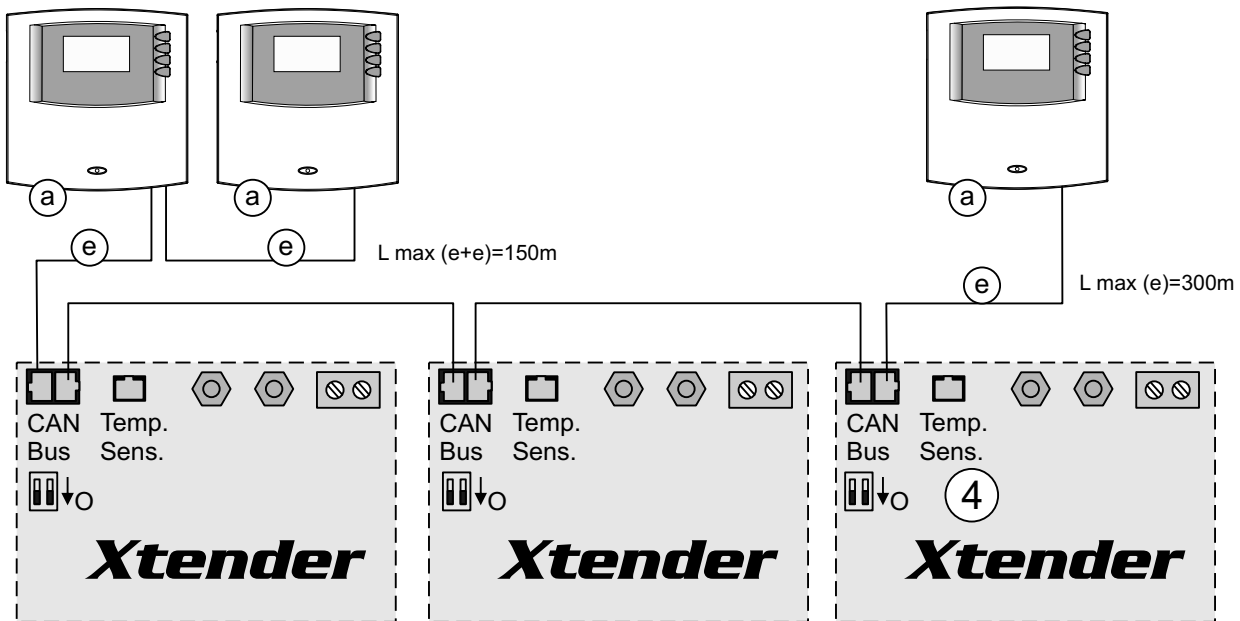
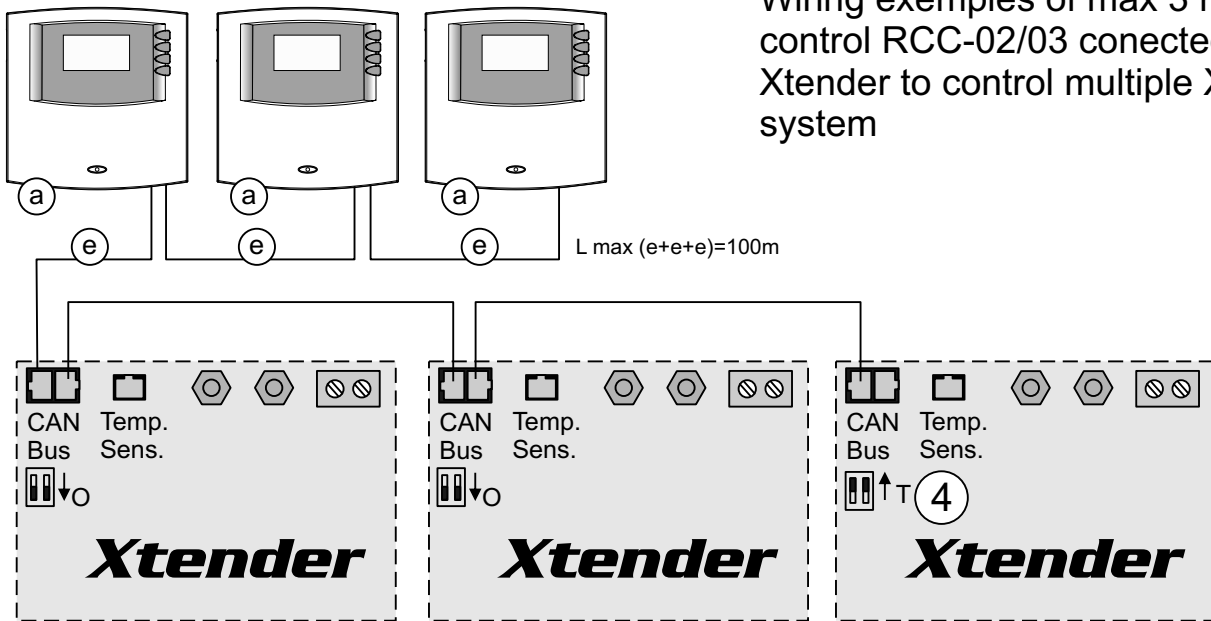

Fig. 19

Wiring examples of max 3 remote control RCC-02/03 connected on Xtender to control multiple Xtender system





Studer Innotec SA
Rue des Casernes 57
1950 Sion – Switzerland
Tél : +41 (0) 27 205 60 80
Fax : +41 (0) 27 205 60 88
info@studer-innotec.com
www.studer-innotec.com